

User Information

SPEEDY ZX4T is the micro-PLC for maximum performance with minimum dimensions. The heart of the control is not a micro-controller, rather an CPLD-chip. This means that SPEEDY runs your program internally absolutely parallel and in real-time – with no cycle times.

Correct Use

SPEEDY ZX4T is used for controlling of the application flow at machinery and equipment. It may not be used for controlling of safety circuits. The compliance to the relevant requirements for installation and operation, especially EN 60204-1, "Electrical equipment of machines", is part of the normal use.

Features

- **High-speed – no cycle times**
- **Extremely compact - only 22.5 / 45mm wide**
- **4 digital inputs / 4 digital transistor outputs (ZX4T) or**
- **9 digital inputs / 2 counter inputs / 8 transistor outputs (ZX4TE)**
- **2 potentiometer connections for adjustable time functions**
- **High interference protection, mains filter, overvoltage protection**
- **Simple programming**
- **Power fail safe**
- **Modular extension facility**
- **Plug-in terminals**



SPEEDY ZX4T



SPEEDY ZX4TE

Scope of Applications

Due to the CPLD technology controlling without any cycle time is provided, because all signals are operated parallelly. So the reaction time will remain constant - regardless of the complexity of the application.

Any problems with different cycle times and corresponding reaction times are things of the past. No matter how fast a packaging machine runs - the cutting will be controlled in an accurately fitting manner and the gluing will be placed at the right position.

For this reason SPEEDY ZX4T is the ideal controller for fast processes at packaging machines, cutting facilities, printing stations, bottling plants, gluing stations, plastic injection moulding machines.

Safety Precautions



- The installation and operation must be carried out by qualified personnel only,
 - who is familiar with the professional handling of machine equipment,
 - who is familiar with the valid rules of industrial safety and accident prevention,
 - who read and understood the operating instructions and the system manual.
- The safe function of the device during machine operation cannot be guaranteed in case of wrong connection or improper operation. This may lead to fatal injuries.
- Pay attention to country specific regulations.
- The electrical installation must be performed after disconnecting the device and the machine from the mains supply.
- The wiring must be carried out according to the instructions of this operating manual.
- The person who programs the device must be protected against electrostatic discharge (ESD protection).
- Opening the device, any manipulation of the device and the avoidance of the safety facilities are not permitted.
- All relevant safety regulations and standards must be attended to.
- Non-observance of the safety regulations may cause death, severe injuries or substantial damage to property.
- Before use, please, read the operating instructions and keep it in a safe place. Make sure that the operating instructions are always available for installation, initial operation and maintenance.

Non-observance of the instructions above will cause the loss of warranty.

User Information

Function

SPEEDY ZX4T controls functions at machines and plants. The functionality will be determined by the loaded program. SPEEDY can be programmed easily with our PC program **EX_PRESS**. The software EX_PRESS is further described in its help system.

In addition to timer and counter functions any logical combinations are programmable between inputs and outputs.

The basic version of SPEEDY ZX4T already is equipped with 4 inputs, 4 short-circuit proof transistor outputs and 2 programmable timers with only 22.5mm wide housing. Each timer has got a long-distance potentiometer connection.

Four time areas cover a range from 100ms to 10min. Additionally division factors can be programmed with the software.

The clock input CK can also be used as a logical digital input, too.

SPEEDY ZX4TE contains an extra plug-in-module in a 45mm housing which provides 5 more inputs, 2 fast counter inputs and 4 extra transistor outputs.

Each input is switched on the hardware side with a signal delay of approx. 100µs to ensure a high interference protection.

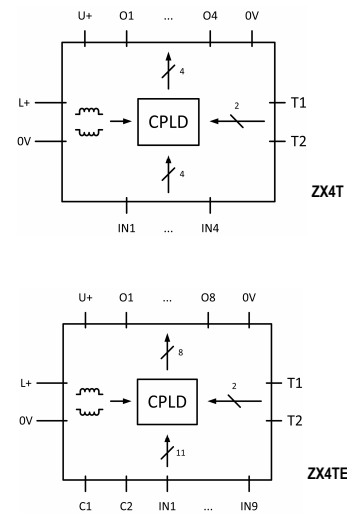

Fig. 1 Block Diagram

Mounting

According to EN 60204-1 the unit is designed to be used in switch cabinets with a minimum environmental protection of IP54. The housing is designed to be mounted on a 35mm DIN-rail according to DIN EN 60715 TH35.

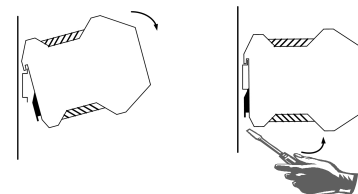

Fig. 2 Mounting / Demounting

Installation

Please, read the section „Safety Precautions“ before installation and initial operation.

- The operating voltage and the voltage for the digital inputs must be generated by a power supply which complies to the regulations of separated extra low voltage (SELV).
- The cable cross-sections may not exceed 2.5mm². Make sure that power is turned off for installation.
- A maximum cable length of the input connections of 1000m at a cable cross-section of 0.75mm² may not be exceeded.
- If the device does not operate after initial start, it must be sent back to the manufacturer unopened. If the device was opened the guarantee claim is void.
- All inductive loads connected to the outputs must be equipped with an effective protection circuit.
- Please consider the information in the section “Technical Data”



Fig. 3 Pluggable terminal blocks

Fast Installation with pluggable terminals blocks, by choice with:
Order-NO. 588592: screw terminals (4 pieces)
Order-NO. 588593: spring cage terminals (4 pieces)

The terminals can be coded unmistakably with the enclosed coding elements

Please order the terminal sets separately.

Terminal Signal

L+	DC 24V Power supply
+U	DC 10..30V for transistor outputs
0V	0V Power supply
IN1..IN9	Inputs 10kHz
C1..C2	Counter inputs 50kHz
O1..O8	Transistor outputs (PNP)
T1-T1	Potentiometer connection Timer1
T2-T2	Potentiometer connection Timer2

All 0V terminals are internally connected.

User Information

Commissioning Procedure

The inputs and outputs must be connected according to the application/circuit diagram. Connection is made via a plug-in screw terminal.

The switching state is indicated by LEDs at the front of the device.

Additional information: see section „Technical Data“

Connection of the operating voltage:

- +24V DC at terminal L+
- 0V at terminal 0V

Fast counter inputs

All inputs can be used as logical or counter inputs. The only difference is the maximum signal frequency. The Inputs In1..In9 (in EX_PRESS up to V4.0b marked with E1...E9) have a standard limit of 10kHz. For fast signals *SPEEDY ZX4TE* has two fast clock inputs C1,C2 with a limit frequency of 50kHz.

Timer function

The ranges of the timers have to be adjusted by the internal outputs T1A and T1B or T2A and T2B according to the following table. The times are valid for an external linear potentiometer (connected to T1-T1 or T2-T2) or a fixed resistor of 100kΩ. Other resistor values are possible and result in corresponding different times. Left-hand-stop of the potentiometers or a jumper result in a calibrated time base of 100ms.

Caution:

If a program is loaded, *SPEEDY ZX4T* will immediately execute the programmed functions after turning on the operating voltage.

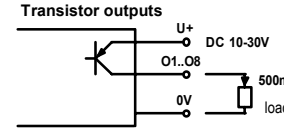
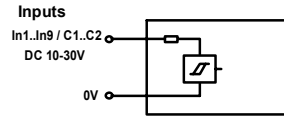

Fig. 4 Inputs / outputs

Note

Up to software-version EX_PRESS V4.0b the inputs are marked with E1..E9, this corresponds to In1..In9; EA10 and EA11 correspond to C1 and C2, the outputs are marked with A1..A8 and correspond to O1..O8.



Fig. 5 External potentiometer DFP1
Order-No. 588420

Timer 1	Timer 2	Timer range
T1A=1; T1B=0	T2A=1; T2B=0	0.1-2.5s
T1A=0; T1B=1	T2A=0; T2B=1	0.3-10s
T1A=0; T1B=0	T2A=0; T2B=0	2-80s
T1A=1; T1B=1	T2A=1; T2B=1	0.3-10min

Fig. 6 Timer adjusting

Download of a Program

The program is created on a PC with the development system EX_PRESS (see help system of EX_PRESS) and it is transferred into the controller. To do this:



1. Open device cover



2. Slide the unit to front



3. Connect device with DC24V and plug in programming cable to the connector. Download program with EX_PRESS, for more information consult the programming system EX_PRESS

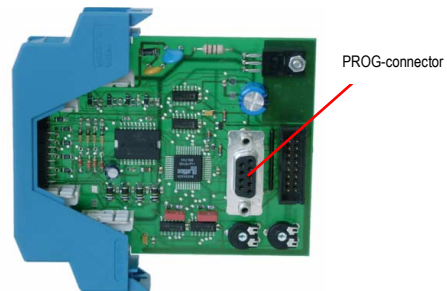

4. Disconnect 24VDC-supply and close the box. Attention! You have to control the fitting in the rails



4a. At ZX4TE insert both units simultaneously. Both printed circuit boards are connected with a flat cable at the reverse side.



User Information

Maintenance No servicing is required. Repairs of the device are only allowed to be made by the manufacturer.

What to do in Case of a Fault?

The device does not execute any function:

- Check the wiring in accordance with the connection diagram.
- Did you download the planned program?

If the fault still persists, the related device must be replaced. The replacement of individual parts of a device is not permitted.

If the fault persists, please, follow the steps which are described in the section "Commissioning Procedure".

Techn. Data

Operating Voltage	DC 24V, +/-20%
Residual ripple	max. 5%
Current consumption	approx. 50mA plus 10mA per activated output
Inputs In1..In9	DC 10-30V, approx. 10kHz
Inputs C1, C2	DC 10-30V, approx. 50kHz
Outputs O1..O8	8 transistors, PNP
Switching capacity	DC 10..30V; 500mA short circuit proof
Timer	2 integrated programmable timer
Time base	external potentiometer at T1-T1 or T2-T2 100ms fixed, 0.1-2.5s; 0.3-10s ; 2-80s; 0.3-10min variable setting via external potentiometers, other times also possible through software
Available internal flags	44 Bit-registers, additional 1 register per output
Time Delay Input/Output	approx. 100µs
Max. input frequency	ca. 50kHz at inputs C1, C2
Capacity of logical combinations	approx. 5000 AND / 300 OR
LEDs	Inputs E1..E9, outputs A1..A8, Pwr
Wire width	max. 2.5mm ²
Protection	IP20
Temperature range	0° C to +50° C
Weight	ZX4T approx. 100g, ZX4TE approx. 200g.

Dimension Drawing

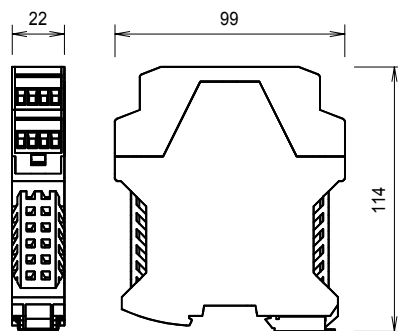

Fig. 7
Dimension SPEEDY ZX4T
(SPEEDY ZX4TE 45mm)

Variants

Order-No. 588400	SPEEDY ZX4T, DC24V, 4 Input, 4 Output, without pluggable terminal blocks
Order-No. 588410	SPEEDY ZX4TE, DC24V, 11 Input, 8 Output, without pluggable terminal blocks
Order-No. 588420	Long-distance potentiometer DFP1, 100kOhm linear, incl. mounting set.
Order-No. 588592	A set of screw terminals, 4 pieces incl. coding elements. 1 set necessary for ZX4T, 2 sets necessary for ZX4TE
Order-No. 588593	A set of spring cage terminals, 4 pieces incl. coding elements. 1 set necessary for ZX4T, 2 sets necessary for ZX4TE
Order-No. 588292	EX_PRESS software for Windows XP/Vista, Programmer with USB cable

B03
B100

E61-214-00